

Technical sheet No 159GM/KAR

1. Supplier name: **GÓRALMET Sp. z o.o.**

Supplier address: **ul. Krakowska 68, 32-860 Czchów, tel/fax 014 6635260**

2. Product name: **GM-1C8 Shortening master link**

3. Description and use: Grade 8 master links with built-in shortening hook for slings and lifting purposes. For use within technical parameters given in point 5 and the Directive 2006/42/EC.

4. The sizes of GM-1C8 links are given as a number which refers to the use of the link in grade 8 chain slings according to EN 818-4 and means size code of a single-leg sling working with an "1,0" safety factor for which the link can be used. Working load limits are given for the normal working conditions. Usage in extreme conditions is not allowed without supplier agreement. It is not allowed to directly connect GM-1C8 links with additional components other than lifting chain. Storage, installation and usage - according to instruction manual or lifting accessories.

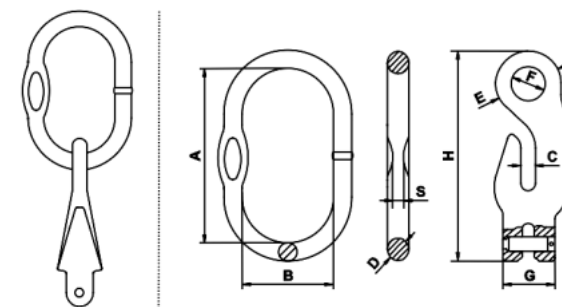

5. Technical parameters:

No	Size [mm]	Nominal dimensions [mm]										Weight [kg/pc]	WLL Working load [t]	MPF Proof force [kN]	BF Breaking force [min. kN]	Material	Coatings	Product code No
		A	B	D	S	H	G	C	E	F	Pin [Ø]							
1	2	3	4	5	6	7	8	9	10	11	12	13	14	15	16	17	18	19
1	6	110	60	13	8,5	106	30,5	8,5	36	18	8,2	0,636	1,12	27,5	43,9	Grade 8 steel: Cr >= 0,40 % Ni >= 0,40 % Mo >= 0,15 % Al >= 0,025 % S <= 0,025 % P <= 0,025 %	Paint	6
2	8	110	60	16	9	150	37	11	48	24	10,5	1,265	2	49	78,5			8
3	10	135	75	20	10	195	48	13,5	60	31	13,4	2,378	3,15	77,2	124			10
4	13	160	90	23	12,5	247	56	16,5	74	36,5	16,7	4,861	5,3	130	208			13

6. Additional informations:

- Safety factor - 4
- $MPF=2,5 \times g \times WLL$, $BF=4,0 \times g \times WLL$ where g - acceleration of gravity in m/s² (i.e. 9,80665)
- Manufacturer and product identification code: GM-1C8
- Traceability code: a four-digit number by formula -YYMM (YY = year of production, MM = month of production)
- Markings: manufacturer's symbol – GMG; ; manufacturer and product identification code; traceability code; product code No; class No – 8
- Marking of pins of 13 mm in diameter and larger: GMG; 8
- Additional informations – label: ; product name; product code No (size); WLL..T; quantity; order No; manufacturer's data and website address.